



20-inch 3D-Intelligent Display

20-3D2W01/00

20-3D2W04/00

User Manual

Philips 3D Solutions

Electrical Safety Warnings

Warning this is a class A product. In a domestic environment this product may cause radio interference in which case the user may be required to take adequate measures.

This display is supplied with a 3-wire power cord. Under no circumstances should the earth wire be disconnected.

To prevent possibility of shock hazard do not expose the display to moisture.

Only qualified service personnel should open the casing cover.

Safety precautions

1. Read these instructions.
2. Keep these instructions.
3. Heed all warnings.
4. Follow all instructions.
5. Do not use this apparatus near water.
6. Clean only with dry cloth.
7. Do not block any ventilation openings. Install in accordance with manufacturer's instructions.
8. Do not install near any heat sources such as radiators, heat registers, stoves, or other apparatus (including amplifiers) that produce heat.
9. Do not defeat the safety purpose of the polarized or grounding-type plug. A polarized plug has two blades with one wider than the other. A grounding type plug has two blades and a third grounding prong. The wide blade or third prong are provided for your safety. If the provided plug does not fit into your outlet, consult an electrician for replacement of the obsolete outlet.
10. Protect the power cord from being walked on or pinched particularly at plugs, convenience receptacles, and the point where they exit from the apparatus.
11. Only use attachments/accessories specified by the manufacturer.
12. Use only with the cart, stand, tripod, bracket, or table specified by the manufacturer, or sold with the apparatus. When a cart is used, use caution when moving the cart/apparatus combination to avoid injury from tip-over.
13. Unplug this apparatus during lightning storms or when unused for long periods of time.
14. Refer all servicing to qualified service personnel. Servicing is required when the apparatus has been damaged in any way, such as power-supply cord or plug is damaged, liquid has been spilled or objects have fallen into the apparatus, the apparatus has been exposed to rain or moisture, does not operate normally, or has been dropped.

Document Information

Info	Content
Title	20 inch 3D Display, User Manual (9922 159 12 051 090401)
Date	01 April 2009
Security	The attached material and the information contained herein are proprietary to Philips 3D Solutions. Copying, reproduction, adaptation, modification or dissemination in whole or part is not permitted without written permission from Philips 3D Solutions.
Contact	www.philips.com/3dsolutions

Table of Contents

1	Introduction.....	6
2	Product features.....	7
2.1	Global product features.....	7
2.2	Technical aspects and details.....	8
2.3	Video input.....	9
3	Scope of supply, Set up and mounting.....	10
3.1	Scope of Supply.....	10
3.2	Safety precautions.....	10
3.3	Installation locations.....	11
3.4	Positioning the display.....	11
3.5	Fitting the table stand.....	11
3.6	Fitting the Cosmetic front.....	12
3.7	Connecting the display.....	12
4	Cleaning instructions.....	13
4.1	Cleaning models 20-3D2W01/00 and 20-3D2W04/00.....	13
5	Software installation.....	14
5.1	Minimum PC requirements.....	14
5.2	Prepare PC.....	14
6	Approbations.....	15
6.1	CE.....	15
6.2	USA and Canada.....	15
6.3	CB Certificate.....	15
6.4	Australia.....	15
7	Environmental.....	16
8	Interfaces.....	17
8.1	DVI-in.....	17
9	Trademarks, Copyrights and disclaimer.....	18
10	References.....	19
11	Technical drawings.....	20

1 Introduction

The 20-inch 3D display is another innovation by Philips 3D Solutions further widening the application scope of advanced 3D display experience. The 20-inch 3D display is specifically designed for a wide range of applications such as digital signage applications in kiosks and many more.

The 3D display offers state-of-the-art lenticular lens design creating a variety of distinct autostereoscopic views. By this the viewer will benefit from the multi-user experience along with a large comfort zone. The display is featuring superior lens design and 3D rendering relying on proven, highly optimized and accurate manufacturing processes.

The display's 2D-plus-depth rendering interface allows maximum flexibility. The 20-inch display provides full compatibility with all other 3D displays in the product range of Philips 3D Solutions. No matter what sort of Philips 3D Solutions display is used, the content does not need regeneration again. What's more, the rendering hardware sits inside the display, allowing for maximum optimisation of the optical system by embedded processing. By this, system integrators are leveraging their investment and they can deploy their 3D content solutions in a much wider range of applications.

The Display Control Tool can be used to change the depth offset, the depth range, the contrast and the brightness.

Philips 3D Solutions offers two models for different application use cases, a generic integration model (frame mount) and a dedicated desktop model:

Product	Type number	Description
Integration model	20-3D2W01/00	Frame mount
Desktop model	20-3D2W04/00	20-3D2W01/00 Table stand Accessories box

A digital version of the 3D Display User Manual can be downloaded from our website:

www.philips.com/3dsolutions.

2 Product features

2.1 Global product features

Multi-view Lenticular Display

- No need for special 3D glasses
- Multiple users experience 3D at the same time
- 9 view autostereoscopic 3D display
- Non-switchable lenticular technology
- Optimal viewing distance: 80 cm
- Full brightness, full contrast
- 2D-plus-depth input in 3D mode
- Protective sheet at the front side of the display

Advanced display signal processing engine

- Flexible 3D data interface based on 2D-plus-depth
- Integrated 3D display processing hardware
- 2D-plus-depth converted to 9 different views and interwoven into a 3D image
- Rendering algorithm is tuned for lenticular optical behaviour
- Two modes:
 - 3D rendering mode
 - 2D transparent mode with picture quality improvement filter

Connectivity

- Display control via DDC/CI channel; no additional RS232 cable needed
- AC switch

2.2 Technical aspects and details

Group	Item	20-3D #	
LCD panel	Type	TFT LCD	
	Resolution	1600 x RGB x 1200	
	Pixel pitch	0.255 mm x 0.255 mm	
	Effective viewing area	408.0 mm x 306.0 mm	
	Size	20.1"	
	Contrast Ratio	800:1	
	Aspect Ratio	4:3	
	Brightness	240 cd/m ²	
	Response time	8 ms	
	Refresh rate	60 fps	
	Display colours	16.7 M (8 bits RGB)	
	White chromaticity	Wx: 0.313 Wy: 0.329 (at 6500°K)	
	Physical	Weight of frame mount	7.1 kg
		Dimensions of frame mount (WxHxD)	435 x 337 x 82 mm
Package dimensions (WxHxD)		531 x 435 x 184 mm	
Mounting – Frame mount: – Desktop:		14x M4 mounting points on the 4 sides VESA MIS-D 100x100 on backside	
Power Consumption		50 W	
Power Consumption standby		2.5 W	
Temperature operating		0 – 35 °C	
Relative humidity		20 % to 80 %	
System MTBF		50K hrs	
Mounting angle		0 – 68° from vertical	
Interface	Video Connector	DVI-D single link	
	Voltage	100 V 60Hz / 230 V 50 Hz	

2.3 Video input

Philips 3D Solutions is not responsible for a poor performance due to a not optimal signal input according to display timing recommendations in the table below:

Advanced Timing				
Horizontal pixels				
	Front porch	40	Sync width	40
	Back porch	132	Active lines	1600
	Sync polarity	+		
Vertical lines				
	Front porch	4	Sync width	4
	Back porch	32	Refresh rate	60 Hz
	Sync polarity	+	Active pixels	1200
			Pixel clock	135 MHz

Signals must comply with the following DVI standard:

Digital Visual Interface DVI Digital Display Working Group Revision 1.0; April 02, 1999
--

3 Scope of supply, Set up and mounting

3.1 Scope of Supply

The contents of the boxes:

- Frame mount 3D 20-inch display box:
 - Assembled intelligent display model: 20-3D2W01/00
 - Safety instruction on paper
- Table stand box:
 - Table stand
 - 4x screws
- Accessories box:
 - Cosmetic front
 - 4x screws
 - DVI cable
 - 3 Main cords (USA, EU and UK)
 - Printed version of the Display user manual (this manual)
 - CD ROM with:
 - Display Control Tool
 - 3DS Media Player
 - User manuals of the software tools
 - 3D Sample content

The desktop model (20-3D2W04/00) consists of the frame mount box (20-3D2W01/00), table stand box and accessories box.

3.2 Safety precautions

Read and follow these instructions when connecting and using your computer display. These instructions are additions to the safety instructions on the start of this manual.

- Unplug the display if you are not going to use it for an extensive period of time.
- Unplug the display if you need to clean it with a slightly damp cloth. The screen may be wiped with a dry cloth when the power is off. See cleaning instructions in chapter 4 for more information.
- Consult a service technician if the display does not operate normally when you have followed the instructions in this manual.
- Keep the display out of direct sunlight and away from stoves or any other heat source.
- Remove any object that could fall into the vents or prevent proper cooling of the display's electronics.
- Keep the display dry. To avoid electric shock, do not expose it to rain or excessive moisture.
- If turning off the display by detaching power cable, wait for 6 seconds before attaching the power cable for normal operation.

- When positioning the display, make sure the power plug and outlet are easily accessible.
- **IMPORTANT:** Always display alternating content with your application. If a still image in high contrast remains on the screen for an extended period of time, it may leave an 'after-image' or 'ghost image' on the front of the screen. This is a well-known phenomenon that is caused by the shortcomings inherent in the LCD technology. Be aware that the after-image symptom cannot be repaired and is not covered under warranty.

3.3 Installation locations

- Avoid exposure to heat and extreme cold.
- Do not store or use the product in locations exposed to heat, direct sunlight or extreme cold.
- Avoid moving the product between locations with large temperature differences. Choose a site that falls within the following temperature and humidity ranges.
 - Temperature: 0-35°C
 - Humidity: 20-80% RH
- Do not subject the product to severe vibration or high impact conditions. Do not place the product inside a car or boot.
- Take care not to mishandle this product by either knocking or dropping during operation or transportation.
- Do not store or use the product in locations where there is a high level of humidity or in dusty environments. Do not allow water or other liquids to spill on or into the product.

3.4 Positioning the display

The display can be integrated (see chapter 11 for drawings), placed on a table stand or wall-mounted. With the desktop model the table stand is supplied; for wall mounting VESA mount points are provided on the frame mount. See the VESA 100x100 standard for the way of mounting.

For the best results, choose a position where light does not fall directly on the screen, and at some distance away from radiators or other sources of heat. Leave a space of at least 10 cm all around the display for ventilation, making sure that curtains, cupboards etc. cannot obstruct the airflow through the ventilation apertures. The display is designed for use in public areas only and should never be operated or stored in excessively hot or humid atmospheres.

3.5 Fitting the table stand

Use only the table stand provided with the set, making sure that the fixings are properly tightened. Avoid using other table stands as they have not been tested in combination with the weight of the display.

Note: When the display faces or shifts downwards after attaching it on the table stand, 2 screws in the table stand needs to be tightened further. One screw in the table stand can be found from the top side and the other screw from the bottom side.

3.6 Fitting the Cosmetic front

The accessories box contains a cosmetic front plus 4 screws. Place the cosmetic front over the display and fix the 4 screws in the holes (2 holes on the left and right side each). Only use screws that are supplied with the accessories box.

3.7 Connecting the display

NEVER (dis)connect DVI when your PC or display is on.

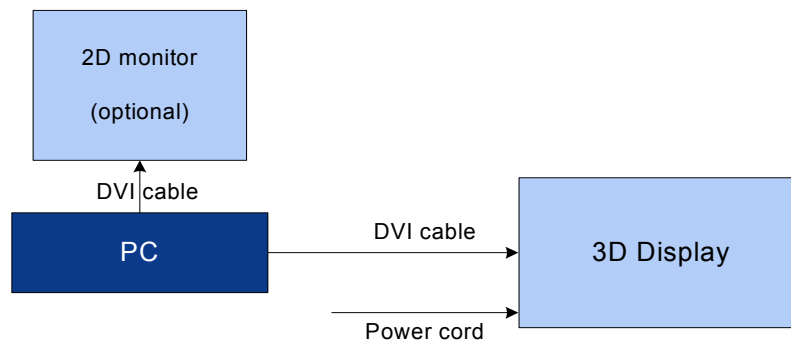

A second 2D display may be connected to the PC. Only use a DVI cable and graphics card that is compliant with the DVI standard (see reference to DVI standard in section 10).

Make sure the PC and Display are switched off!

1. Connect the PC via the DVI cable to the DVI connector.
2. Connect the power cord.

4 Cleaning instructions

CAUTION: Using the wrong instructions might damage (parts of) the intelligent display. Note that isopropyl alcohol causes damage.

4.1 Cleaning models 20-3D2W01/00 and 20-3D2W04/00

Before cleaning the display, disconnect the power cord and DVI cable.

It is preferable to clean the front of the display with the cleaning products listed in the table below.

To clean we recommend:

cleaning materials	e.g. soft cotton cloth window leather
Aqueous solution, neutral and weakly alkaline window cleaner without additives of abrasive substances: Permitted portion of ammonia < 5 Vol-%, as well as water soluble organic solvents < 5 Vol-%.	e.g. Flux Ajax

Do not use for cleaning:

alkaline lyes	e.g. durd soap, certain textile detergents
lyes	e.g. toilet cleaner
acids	e.g. hydrochloric acid, vinegar, lemon
decalcification agent	e.g. citric acid
degreasing agent	e.g. acetone, methylene chloride, trichloroethylene, petrol
Strong ammonia detergents	e.g. Toilet cleaner
chlorine or Hypochloride detergents	e.g. Chavel water, Domestos
solvents	e.g. Ethyl alcohol, Isopropyl alcohol , alcohol, acetone, trichloroethylene, benzene, hexane, petrol
coarse millinery	e.g. abrasive, steel wool, sponge with abrasives, blades cloth with thread made of steel, hard cloth or paper tissue
Other	Electrolube ASC, REF ASC250ml

As an alternative, clean the front of the display with a solution of soft soap (e.g. liquid hand soap) and tepid water, using a soft cloth or sponge.

The rest of the display can be cleaned with a dry cloth.

01 April 2009

5 Software installation

This chapter contains the prerequisites for the PC hardware and the operating system for the software. First check if your PC complies with the requirements that are given in the next sections. Then follow the installation instructions, where you are guided step by step through the software installation procedure.

5.1 Minimum PC requirements

The PC must comply with the following requirements:

- Intel Pentium 4 (≥ 3 GHz), Intel Core2Duo (≥ 1.86 GHz) or faster
- ≥ 512 MB RAM
- 7200 rpm hard disk with 8 Mbyte cache (minimal sustained throughput 10 MB/s)
- CD/DVD ROM player
- Graphics card based on NVIDIA 6800 or 7800 chipsets
- Microsoft Windows XP SP2

5.2 Prepare PC

Make sure that the following software is installed on the PC before connecting the 3D Display to the PC:

- Windows XP, upgraded to Service Pack 2
- NVIDIA Display driver

6 Approbations

6.1 CE

EN 60950-1:2001
EN 55022: 1998-09; cor 1: 1999-08; A1: 2000-10; A2: 2003-01; cor 2: 2003-07
EN 55024: 1998-09; A1: 2001-10; A2: 2003-01
EN 61000-3-2: 2000-12
EN 61000-3-3: 1995-01; A1: 2001-06

6.2 USA and Canada

cETLus listing
UL 60950
Can/CSA 60950
FCC part 15B: 2004-10 Class A
ANSI C63.4: 2001; 2003

6.3 CB Certificate

IEC 60950-1: 2001 (1st edition)
IEC 61000-3-2: 2000-08; A1: 2001-08; A2: 2004-10
IEC 61000-3-3: 1994-12; A1: 2001-01

6.4 Australia

C-tick

7 Environmental

Condition	Operating	Shipping / storage
Temperature	0 °C to 35 °C	-20 °C to 60 °C
Humidity	20 % - 80 % No condensation	0% - 95 % No condensation
Air pressure	600 – 1100 mBar	300 – 1100 mBar

The display is designed for indoor usage only.

8 Interfaces

8.1 DVI-in

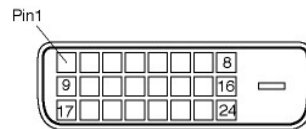

Pin	Signal	Pin	Signal	Pin	Signal
1	T.M.D.S. Data2-	9	T.M.D.S. Data1-	17	T.M.D.S. Data0-
2	T.M.D.S. Data2+	10	T.M.D.S. Data1+	18	T.M.D.S. Data0+
3	T.M.D.S. Data2/4 Shield	11	T.M.D.S. Data1/3 Shield	19	T.M.D.S. Data0/5 Shield
4	No connect	12	No connect	20	No connect
5	No connect	13	No connect	21	No connect
6	DDC Clock	14	+5V Power	22	T.M.D.S. Clock Shield
7	DDC Data	15	Ground (for +5V)	23	T.M.D.S. Clock+
8	No connect	16	Hot Plug Detect	24	T.M.D.S. Clock-

The DDC Clock and the DDC data are used by the Display Control Tool to control depth and colour settings in the display.

9 Trademarks, Copyrights and disclaimer

Specifications are subject to change without notice.
Trademarks are the property of Koninklijke Philips Electronics N.V. or their respective owners.
2009 © Koninklijke Philips Electronics N.V. All rights reserved.

10 References

The next references are not normative but informative.

Description
VESA Display data channel standard; Version 3; December 15, 1997
VESA Display data channel command interface (DDC/CI) standard; Version 1; August 14, 1998
Digital Visual Interface DVI; Digital Display Working Group; Revision 1.0; April 02, 1999
VESA enhanced extended display identification data standard; Release A, Revision 1; February 9, 2000
ITU-R BT.709.4; Parameter values for HDTV standards for production and international programme exchange;
VESA Flat Display Mounting Interface Standard (FDMI); Version 1, Revision 1; January 16, 2006;

11 Technical drawings

For integration purposes the following drawings are added for your convenience.

