

42-inch 3D-Intelligent Display

42-3D6C01/00

42-3D6W01/00

42-3D6C02/00

42-3D6W02/00

User Manual

Philips 3D Solutions

Safety Instructions for 3D display

Read and follow these instructions:

1. This product must be earthed.
2. Use only an approved power cord or interconnection cable.
3. Unplug the product if you are not going to use it for a long period of time.
4. Unplug the product if you need to clean it, use a slightly damp cloth. Never use alcohol, solvents or ammonia-based liquids.
5. Refer all servicing to qualified service personnel
6. Do not block any ventilation holes.
7. To avoid electric shock, do not expose to rain or excessive moisture.
8. Do not store or use the product in locations exposed to excessive heat, direct sunlight, extreme cold or in dusty environments.
9. Avoid moving the product between locations with large temperature differences.
10. Choose a location within the following temperature and humidity ranges.
 - Temperature: 0- 35°C
 - Humidity : 20-80% RH
11. Avoid hitting or dropping during operation and transportation.

Instructions de sécurité pour l'écran 3D

Prière de lire et respecter les instructions suivantes :

1. Cet appareil doit être connecté à la terre.
2. Utilisez uniquement un cordon d'alimentation ou un câble d'interconnexion approuvé.
3. Déconnectez l'appareil si vous ne l'utilisez pas pendant une période prolongée.
4. Déconnectez l'appareil pour le nettoyer ; utilisez un chiffon légèrement humidifié. Ne jamais utiliser de l'alcool, des solvants ou des produits à base d'ammoniac.
5. Confiez les opérations d'entretien au personnel d'entretien qualifié.
6. Ne pas bloquer les orifices d'aération.
7. Afin d'éviter tout choc électrique, ne pas exposer l'appareil à la pluie, ni à un taux d'humidité excessif.
8. Ne pas entreposer ni utiliser l'appareil dans des lieux poussiéreux ou exposés à une chaleur excessive, aux rayons du soleil ou à des températures excessivement basses.
9. Évitez de transporter l'appareil entre deux endroits entre lesquels il y a une grande différence de température.
10. Veillez à ce que le lieu d'entreposage ou d'utilisation ait les caractéristiques de température et de taux d'humidité suivantes :
 - Température: 0-35°C
 - Humidité relative : 20-80%
11. Évitez les chocs ou la chute de l'appareil pendant son utilisation ou pendant le transport.

Warning this is a class A product. In a domestic environment this product may cause radio interference in which case the user may be required to take adequate measures.

Document Information

Info	Content
Title	42 inch 3D Display, User Manual (9922 159 01 73 I 080923)
Date	23 September 2008
Security	The material and the information contained herein are proprietary to Philips 3D Solutions. Copying, reproduction, adaptation, modification or dissemination in whole or part is not permitted without the prior written consent of Philips 3D Solutions.
Contact address	Philips 3D Solutions High Tech Campus 27 5656 AE Eindhoven The Netherlands, E-mail support: 3DService@philips.com E-mail general: 3DSolutions@philips.com Website: www.philips.com/3D

Table of Contents

1	Introduction	6
2	Product features.....	7
2.1	Global product features	7
2.2	Technical aspects and details.....	8
2.3	Cosmetic specifications	9
3	Scope of supply, Set up and mounting.....	12
3.1	Scope of Supply	12
3.2	Image retention	12
3.3	Installation locations.....	12
3.4	Mounting.....	13
3.5	Positioning the display.....	13
3.6	Connecting the display	14
3.7	Cleaning instructions.....	15
3.8	Disposal of your old product.....	16
4	Software installation.....	17
4.1	Minimum PC requirements	17
4.2	Prepare PC	17
5	Approbations	18
5.1	CE.....	18
5.2	USA and Canada	18
5.3	CB Certificate.....	18
6	Environmental.....	19
7	Interfaces.....	20
7.1	DVI-in.....	20
7.2	LED.....	20
8	Trademarks, Copyrights and disclaimer	21
9	Manufacturer / Support.....	22
10	Mounting bracket.....	23
11	References	26

1 Introduction

The 42-inch 3D display from Philips 3D Solutions offers state-of-the-art lenticular lens design creating a variety of distinct autostereoscopic views. By this the viewer will benefit from the multi-user experience along with a large comfort zone. The 42-inch 3D display is specifically designed for a wide range of applications such as digital signage and information provision.

The display is featuring superior lens design and 3D rendering relying on proven, highly optimized and accurate manufacturing processes. The lens design minimizes cross talk, creating highly distinct views. The 42-3D6C01/00 and 42-3D6C02/00 are designed for optimal viewing comfort. The 42-3D6W01/00 and 42-3D6W02/00 are designed for maximum WOW viewing experience.

The display's 2D-plus-depth rendering interface is open, allowing maximum flexibility. No matter what sort of Philips 3D Solutions display is used, the content does not need regeneration. What's more, the rendering hardware sits inside the display, allowing for maximum optimisation of the optical system by embedded processing.

Provided with the 42-inch 3D display are the 3DS Media Player and the Display Control Tool. The Display Control Tool can be used to set all kinds of visualisation parameters for the 3D display; examples are the WOW offset, the WOW range, the contrast, and the brightness. The 3DS Media Player is used for play-out for the Philips 3D Solutions 3D displays. It takes care that the display switches to 3D mode with the appropriate 3D visualization settings.

After registration a digital version of the 3D Display User Manual can be downloaded from our website: www.philips.com/3Dsolutions.

2 Product features

2.1 Global product features

Multi-view Lenticular Display

- 9 view autostereoscopic 3D display
- Non-switchable lenticular technology
- Optimal viewing distance: 3 meters (10 feet).
- Wide comfort zone for 3D perception
- Full brightness, full contrast
- 2D-plus-Depth or Declipse input in 3D mode ¹
- Protective plate at the front side of the display

Advanced display signal processing engine

- Integrated 3D display processing hardware
- Open 3D data interface
- 2D-plus-Depth converted to 9 different views and interwoven into a 3D image
- Rendering algorithm is tuned for lenticular optical behaviour
- Two modes:
 - 3D rendering mode
 - 2D transparent mode with picture quality improvement filter

Connectivity

- Display control via DDC/CI channel; no additional RS232 cable needed
- AC switch
- A LED indicates 'power on' and 'standby' mode

¹ For an elaborate explanation on the WOWvx display interface formats see the '3D Interface Specifications - white paper' and '3D Content Creation Notes' documents. Both can be downloaded from the download section on <http://www.philips.com/3dsolutions>.

2.2 Technical aspects and details

Group	Item	42-3D #
LCD panel	Type	TFT LCD
	Resolution	1920 x RGB x 1080
	Pixel pitch	0.4845 mm x 0.4845 mm
	Effective viewing area	930.24 mm x 523.26 mm
	Size	42"
	Contrast Ratio	1500:1
	Aspect Ratio	16:9
	Brightness	500 cd/m ²
	Response time	8 ms (gray-to-gray)
	Refresh rate	60 fps
	Display colors	16.7 M (8 bits RGB)
	White chromaticity	Wx: 0.280 Wy: 0.285 (at 10500°K)
Physical	Weight (including table stand)	42-3D6C #: 32 kg 42-3D6W #: 35 kg
	Dimensions (WxHxD)	1017 x 610 x 128 mm
	Package dimensions (WxHxD)	1176 x 791 x 318 mm
	Installation	Table stand (included) wall, or ceiling mounting bracket or free-standing (optional)
	Power Consumption	230 W
	Power Consumption standby	2.5 W
	Operating temperature	0 - 35 °C
	Relative humidity	20 % to 80 %
	System MTBF	50K hrs
	Installation angle	0 - 10° from vertical
Interface	Connector	DVI-D single link
	Voltage	110 – 230 V, 50 – 60 Hz

2.3 Cosmetic specifications

2.3.1 Description

This specification standard is applicable to:
3D-displays supplied by Philips 3D Solutions.

2.3.2 Environmental conditions of inspection

The environmental conditions and visual inspection shall be conducted as below.

Ambient temperature in the range 15-25 [°C].

Humidity in the range 25-75 [%RH].

The functional inspection distance of the monitor (measured between the monitor and the inspector's sight) should be at least 3.0 [m].

The maximal viewing angle relative from the normal direction of the module/monitor is specified according to $\pm Y$ degree to the front surface of the display in vertical direction, and $\pm X$ degree to the front surface of the display in horizontal direction. The values below are the following: X = 15, Y = 45.

Ambient illumination:

- External appearance inspection in the range 400-600 [Lux].

Light on inspection in the range 100-200 [Lux].

2.3.3 Classification of defects

The defects are classified as major and minor defects. The definition of defects is described as follows:

Major defect:

The defect may cause functional failure, or reduce the usability of the product for its purpose. For example: electrical failure, deformation, etc.

Minor defect:

The defect does not reduce the usability of the product for its purpose. For example: dot defect, etc.

The judgement of the major and minor defects shall be according to the table with classification of defects below.

Inspection item	Description	Defect type
Vertical line	Abnormal line appears in vertical direction.	Major
Horizontal line	Abnormal line appears in horizontal direction.	Major
Cross line	Abnormal cross line appears in display.	Major
No display	No signal output in display.	Major
Irregular display	Abnormal signal outputs in display.	Major
Dot defect	Bright dot, dark dot or dot adjacent appear in display.	Minor
Foreign material	Foreign material appears in display	Minor

2.3.4 Inspection Criteria

Definition of dot defect:

If the size of a dot defect is larger than 0.5 times a single pixel, it can be regarded as one dot defect

Bright dot: Dot appears bright and the size is fixed in a black pattern.

Dark dot: Dot appears dark and the size is fixed in pure red, green and blue pattern.

2.3.4.1 Display defects

The size of a circular area is defined by the average of the size along the horizontal axis (=a) and the vertical axis (=b), i.e. $D=(a+b)/2$. The size of a lint/scratch is defined by its width (=W) and its length (=L).

Item 3D-display		Maximum tolerance
Bright dot	Random	$N \leq 3$
	2 dots adjacent	$N \leq 1$
	3 dots adjacent or more	$N \leq 0$
Dark dot	Random	$N \leq 12$
	2 dots adjacent	$N \leq 2$
	3 dots adjacent or more	$N \leq 1$
	Minimum distance between dark dots	$L \geq 15$ [mm]
Total bright and dark dots		$N \leq 12$
Backlight	Break down	Not permitted
Connector	Oxidized/rusty connector not acceptable	

Item protective plate	Maximum tolerance
Protective plate scratches	$0.15 < W \leq 0.25$ [mm], $0.3 < L \leq 10.0$ [mm], $N \leq 7$

Item 3D-display		Maximum tolerance
LED function	See paragraph 7.2	Failure not acceptable
Cosmetic profiles	Scratches	$0.05 < W \leq 0.15$ [mm], $0.3 < L \leq 2.0$ [mm], $N \leq 7$
	Sharp edges	Not allowable.
Outside and connectors	Cracks and Rust	Not acceptable under any circumstances.

Disclaimer will be printed on bag sticker and included in this manual

- Please be aware that the protective plate in front of this display is sensitive for scratching during cleaning. This is caused by hard particles (like sand) that might be present in the cloth used and/or the cleaning fluid.
- Small backlight intensity variations can occur in dark backgrounds
- Discoloration of the active area circumference can occur and should be treated as normal and will not change the functional performance of the 3D intelligent display.
- Philips 3D Solutions is not responsible for a poor performance due to a not optimal signal input according to display timing recommendation below

Advanced Timing				
Horizontal pixels	Front porch	152	Sync width	48
	Back porch	48	Scan rate	67.02 kHz
	Sync polarity	+	Active lines	1920
Vertical lines	Front porch	5	Sync width	5
	Back porch	26	Refresh rate	60.054 Hz
	Sync polarity	+	Active pixels	1080
			Pixel clock	145.30 MHz

Signals must comply with the following DVI standard: Digital Visual Interface DVI
 Digital Display Working Group
 Revision 1.0; April 02, 1999

3 Scope of supply, Set up and mounting

3.1 Scope of Supply

The contents of the box:

- Display 42-3D #
- Table stand
- 3 Mains cords (USA, EU and UK)
- DVI cable
- CD ROM with:
 - Display Control Tool
 - 3DS Media Player
 - User manuals
 - 3D Sample content ²
- Printed version of the Display user manual (this manual)
- Cardboard box with cushions

The following items can be purchased separately:

- Mounting bracket (Article code: 42-WM)

3.2 Image retention

IMPORTANT: Always display alternating content with your application. If a still image in high contrast remains on the screen for an extended period of time, it may leave an 'after-image' or 'ghost image' on the front of the screen. This is a well-known phenomenon, caused by the shortcomings inherent in the LCD technology. Please note that the after-image symptom cannot be repaired and is not covered under warranty.

3.3 Installation locations

- Avoid exposure to excessive heat and extreme cold.
- Do not store or use the product in locations exposed to excessive heat, direct sunlight or extreme cold.
- Avoid moving the product between locations with large temperature differences. Choose a site that falls within the following temperature and humidity ranges.
 - Temperature: 0-35°C
 - Humidity: 20-80% RH
- Do not subject the product to severe vibration or high impact conditions. Do not place the product e.g. inside a car, car boot or trunk.
- Take care not to mistreat this product by either hitting it or dropping it during operation or transportation.
- Do not store or use the product in locations where there is a high level of humidity or in dusty environments. Do not allow water or other liquids to spill on or into the product.

² More sample content can be downloaded from <http://www.wowvx.com>, <http://www.philips.com/3D> or the Extranet at <http://www.philips.com/3dsolutions> (registration required).

3.4 Mounting

The display can be placed on a table stand or wall-mounted. The table stand is supplied as standard; the mounting bracket can be purchased separately. This bracket can also be used as an adapter in combination with universal wall supports, ceiling supports or universal floor stands (e.g. Vogel's Professional).

3.4.1 Fitting the table stand

Only use the stand supplied with the set, making sure that the fasteners are properly tightened. Never use a makeshift stand, or legs fixed using woods crews.

3.4.2 Using the mounting bracket

The standard VESA mount holes on the mounting bracket allow the user to install the Philips 3D display on any VESA MIS-E compatible wall support, ceiling support or floor stand.

Important: Use a VESA MIS-E compatible support suitable for the weight of this 3D Display.

Always secure the mounting bracket to the display using 4 screws. This helps avoid potentially dangerous situations when lifting the display out of the mounting bracket.

3.5 Positioning the display

For the best results, choose a place where there is no direct light shining onto the screen, and which is some distance away from radiators or other sources of heat. Leave a space of at least 10 cm all around the display for ventilation, making sure that curtains, cupboards etc. cannot obstruct the airflow through the ventilation apertures. The display is intended for use in a public places only and should never be operated or stored in excessively hot or humid conditions.

3.6 Connecting the display

NEVER (dis)connect DVI when your PC or Display is on.

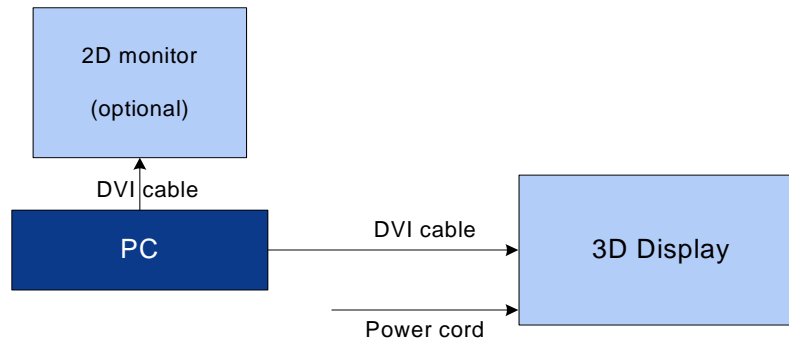

A second 2D display may be connected to the PC. Only use a DVI cable and graphics card that is compliant with the DVI standard (see reference to DVI standard in **Error! Reference source not found.**)

The picture below show the DVI-connector and power connector on the back of the display

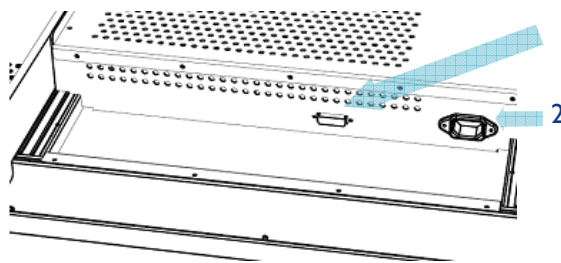

Make sure the PC and Display are switched off!

1. Connect the PC via the DVI cable to the DVI connector.
2. Connect the power cord.

3.7 Cleaning instructions

Before cleaning the display, disconnect the power cord and DVI cable.

It is preferable to clean the front of the display with the cleaning products listed in the table below.

To clean we recommend:

cleaning materials	e.g. soft cotton cloth window leather
Aqueous solution, neutral and weakly alkaline window cleaner without additives of abrasive substances: Permitted portion of ammonia < 5 Vol-%, as well as water soluble organic solvents < 5 Vol-%.	e.g. Flux Ajax

Do not use for cleaning:

alkaline lyes	e.g. durd soap, certain textile detergents
lyes	e.g. toilet cleaner
acids	e.g. hydrochloric acid, vinegar, lemon
decalcification agent	e.g. citric acid
degreasing agent	e.g. acetone, methylene chloride, trichloroethylene, petrol
Strong ammonia detergents	e.g. Toilet cleaner
chlorine or Hypochloride detergents	e.g. Chavel water, Domestos
solvents	e.g. Ethyl alcohol, Isopropyl alcohol, alcohol, acetone, trichloroethylene, benzene, hexane, petrol
coarse millinery	e.g. abrasive, steel wool, sponge with abrasives, blades cloth with thread made of steel, hard cloth or paper tissue
Other	Electrolube ASC, REF ASC250ml

As an alternative, clean the front of the display with a solution of soft soap (e.g. liquid hand soap) and tepid water, using a soft cloth or sponge.

The rest of the display can be cleaned with a dry cloth.

3.8 Disposal of your old product

Your product is designed and manufactured with high quality materials and components, which can be recycled and reused.

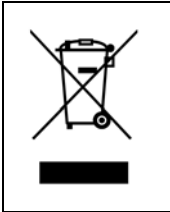

When this crossed-out wheeled bin symbol is attached to a product it means the product is covered by the European Directive 2002/96/EC

Please inform yourself about the local separate collection system for electrical and electronic products.

Please act according to your local rules and do not dispose of your old products with normal household waste. The correct disposal of your old product will help prevent potential negative consequences for the environment and human health.

4 Software installation

This chapter contains the prerequisites for the PC hardware and the operating system for the software. First, check whether your PC complies with the requirements that are given in the next sections. Then follow the installation instructions, where you will be guided step by step through the software installation procedure.

4.1 Minimum PC requirements

The PC must comply with the following requirements:

- Pentium 4, ≥ 3 GHz or Dual core ≥ 1.7 GHz
- ≥ 512 MB internal memory for Windows XP, ≥ 1024 MB internal memory for Windows Vista
- 7200 rpm hard disk with 8 Mbyte cache (minimal sustained throughput 10 MB/s)
- DVD ROM player
- Graphics card:
 - based on NVIDIA for example 7600 or 8600 chipsets,
 - or based on NVIDIA Quadro for example FX1400 (windows XP only),
 - or based on ATI for example X1650 (Windows XP only).
- Windows XP SP2 or Windows Vista (see above for restrictions concerning graphics cards)

4.2 Prepare PC

Make sure that the following software is installed on the PC before connecting the 3D Display to the PC:

- Windows XP (upgraded to Service Pack 2) or Windows Vista
- NVIDIA Display driver or ATI Driver (Windows XP only)

5 Approbations

5.1 CE

EN 60950-1:2001
EN 55022: 1998-09; cor 1: 1999-08; A1: 2000-10; A2: 2003-01; cor 2: 2003-07
EN 55024: 1998-09; A1: 2001-10; A2: 2003-01
EN 61000-3-2: 2000-12
EN 61000-3-3: 1995-01; A1: 2001-06

5.2 USA and Canada

cETLus listing
UL 60950
Can/CSA 60950
FCC part 15B: 2004-10 Class A
ANSI C63.4: 2001; 2003

5.3 CB Certificate

IEC 60950-1: 2001 (1st edition)
IEC 61000-3-2: 2000-08; A1: 2001-08; A2: 2004-10
IEC 61000-3-3: 1994-12; A1: 2001-01

6 Environmental

Condition	Operating	Shipping / storage
Temperature	0 °C to 35 °C	-20 °C to 60 °C
Humidity	20 % - 80 % No condensation	0% - 95 % No condensation
Air pressure	600 – 1100 mBar	300 – 1100 mBar

The display is only used indoor.

7 Interfaces

7.1 DVI-in

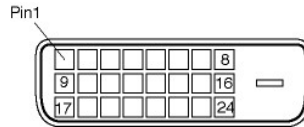

Pin	Signal	Pin	Signal	Pin	Signal
1	T.M.D.S. Data2-	9	T.M.D.S. Data1-	17	T.M.D.S. Data0-
2	T.M.D.S. Data2+	10	T.M.D.S. Data1+	18	T.M.D.S. Data0+
3	T.M.D.S. Data2/4 Shield	11	T.M.D.S. Data1/3 Shield	19	T.M.D.S. Data0/5 Shield
4	No connect	12	No connect	20	No connect
5	No connect	13	No connect	21	No connect
6	DDC Clock	14	+5V Power	22	T.M.D.S. Clock Shield
7	DDC Data	15	Ground (for +5V)	23	T.M.D.S. Clock+
8	No connect	16	Hot Plug Detect	24	T.M.D.S. Clock-

The DDC Clock and the DDC data are used by the Display Control Tool to control depth and colour settings in the display.

7.2 LED

LED Color	Status
Red	Display is in standby mode. No DVI clock is present.
Green	Display on

8 Trademarks, Copyrights and disclaimer

Specifications are subject to change without notice.

Trademarks are the property of Koninklijke Philips Electronics N.V. or their respective owners.

2005 © Koninklijke Philips Electronics N.V. All rights reserved.

9 Manufacturer / Support

Philips 3D Solutions combine the vibrancy of a young company with experience that stretches back to the earliest days of the modern 3D movement. Our skills, combined with the resources of Philips, mean that Philips 3D Solutions can support your business at every link in the 3D value chain. We provide complete 3D solutions - everything from displays and signal processing to licensing of our state-of-the-art technology.

More than any other factor, the skills of our people have given Philips 3D Solutions a head start in 3D. Some of our colleagues have been working in 3D since the mid-1990s. The intellectual capital that we have accumulated is constantly being reinvested in new projects and ideas, helping Philips 3D Solutions strengthen its position as a leader in 3D technology.

We are part of the Philips community, one of the world's biggest electronics companies. Philips 3D Solutions can rely on the expertise and worldwide distribution networks of Philips, allowing us to match your requirements and needs. We can offer a complete solution, which in the 3D world is not just a matter of convenience, but of quality. As your partner in design, Philips 3D Solutions can help you shorten your time to market.

The Philips 3D Solutions team shares your excitement about the world of 3D technology, and we are ready, willing and able to forge a business relationship with you. We hope this manual answers your questions about Philips 3D Solutions. If you still have questions, or if you wish to discuss possible business opportunities with us, one of our representatives will be happy to speak with you.

Any questions? Please contact

Philips 3D Solutions

Email: 3DService@philips.com for support questions, or 3DSolutions@philips.com for general/other questions.

10 Mounting bracket

The mounting bracket is not supplied as standard with the 3D Display. It must be purchased separately with article code: 42-WM.

Installation instructions are supplied with the mounting bracket. Please read these carefully and act accordingly. This chapter contains the dimensions of the mounting bracket.

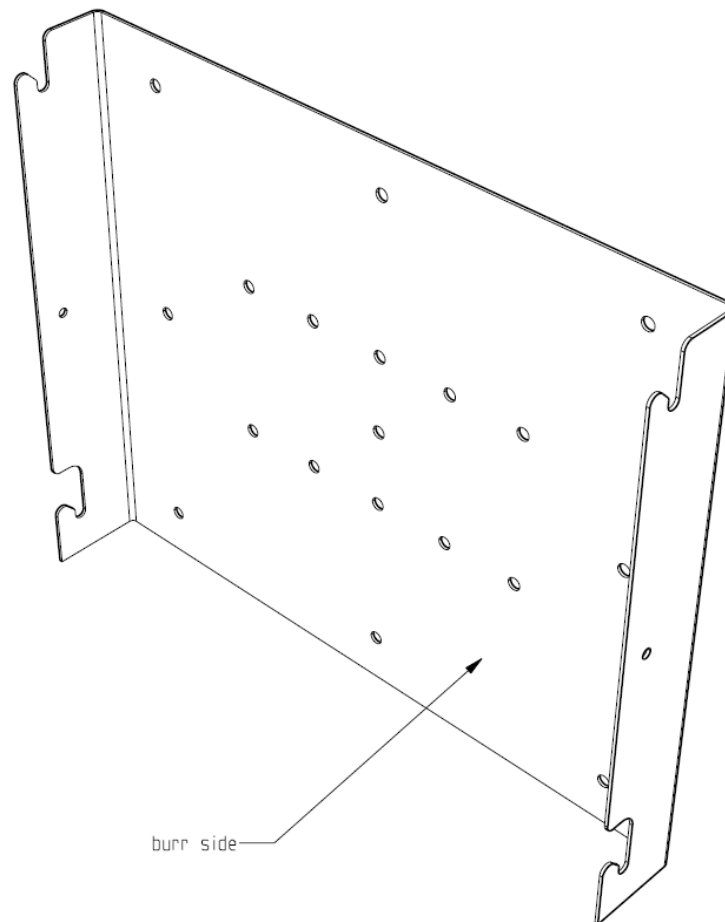

Hole pattern on mounting bracket:

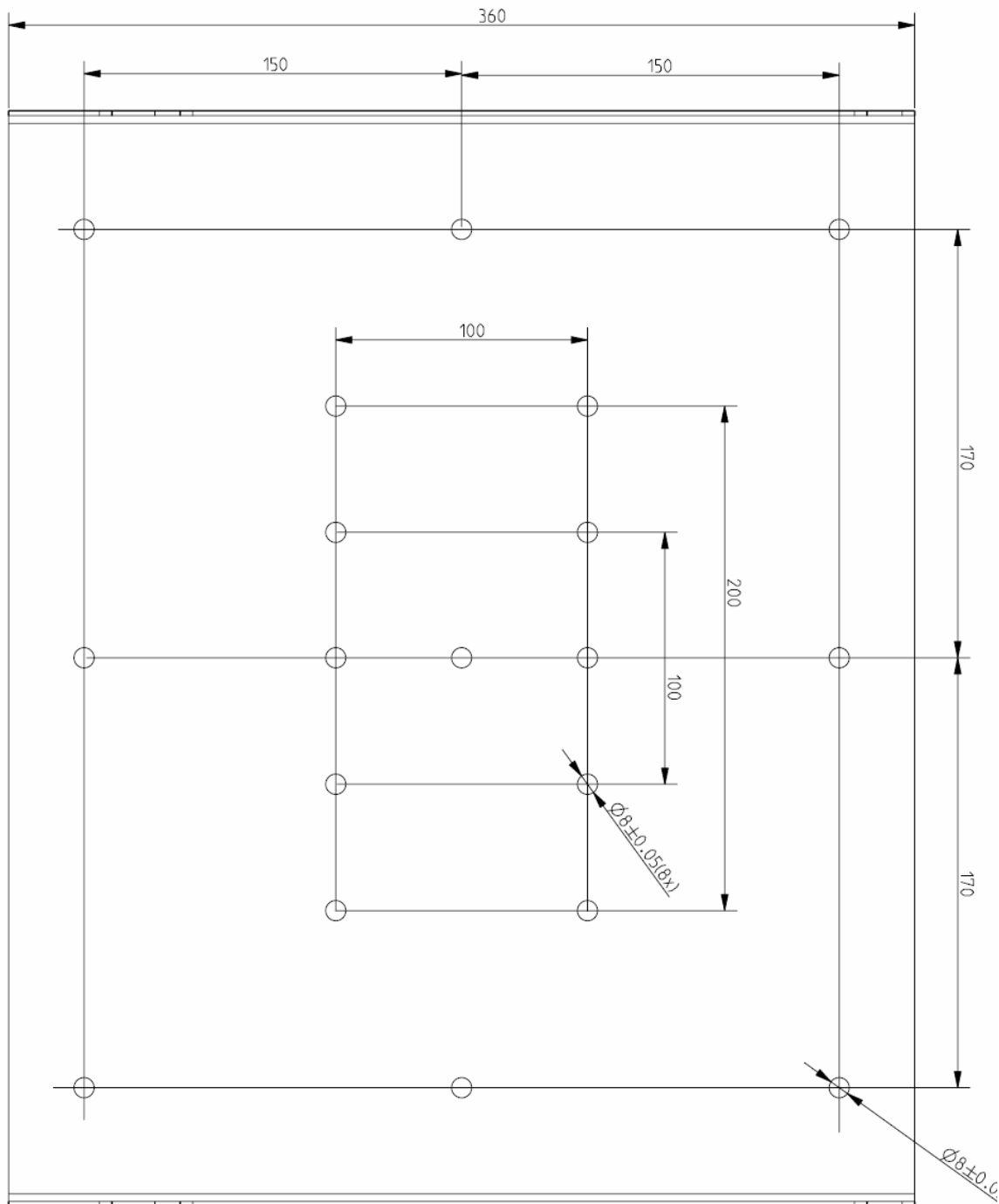

Location of mounting bracket relative to display (Rear view).

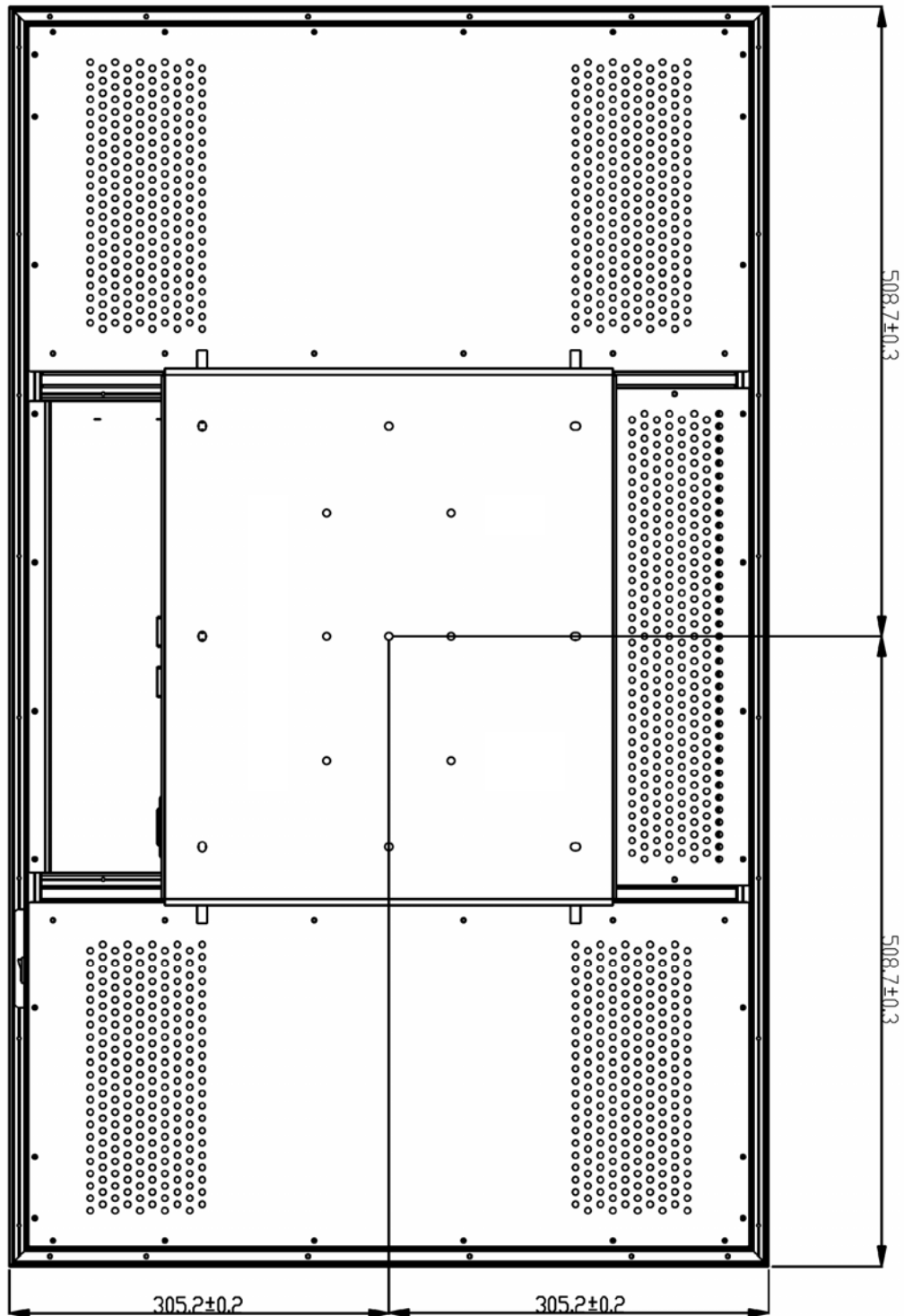

11 References

The following references are not normative but informative.

Description
VESA Display data channel standard; Version 3; December 15, 1997
VESA Display data channel command interface (DDC/CI) standard; Version 1; August 14, 1998
Digital Visual Interface DVI; Digital Display Working Group; Revision 1.0; April 02, 1999
VESA enhanced extended display identification data standard; Release A, Revision 1; February 9, 2000
ITU-R BT.709.4; Parameter values for HDTV standards for production and international programme exchange;

- 0 - 0 - 0 - 0 - 0 -